



Automotive Equipment

4000 StepLine



- EN Automatic Tyre Changer
- IT Smontagomme Automatico
- DE Automatische Reifenmontiermaschine

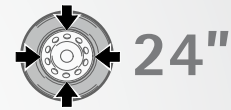

*HTB24 helper optional
helper a richiesta
Helper auf Anfrage
code 8-11900260

HELPER HTB21 OPTIONAL

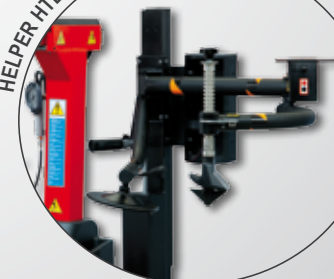

HELPER HTB21 optional (code 8-11900261)

Universal multifunctional device for facilitating tyre mounting and demounting

HELPER HTB21 a richiesta (code 8-11900261)

Dispositivo multifunzionale universale per agevolare montaggio e smontaggio pneumatico

HELPER HTB21 auf Anfrage (Artikelnummer 8-11900261)

Universelle Mehrzweckvorrichtung zur Erleichterung der Reifenmontage- und demontage

Automatic tyre changer for cars, lightweight transport vehicles and motor vehicles

Smontagomme automatico per autovetture, trasporto leggero, motoveicoli e scooter

Automatische Reifenmontiermaschine für PKWs, Kleintransporter, Motorräder und Motorroller



Automotive Equipment

Automatic Tyre Changer Smontagomme Automatico Automatische Reifenmontiermaschine

TECHNICAL DATA - DATI TECNICI - TECHNISCHE DATEN

OUTSIDE CLAMP	PRESA ESTERNA	SPANNBEREICH AUSSEN	11" - 24"
INSIDE CLAMP	PRESA INTERNA	SPANNBEREICH INNEN	13" - 26"
MAX. WHEEL DIAMETER	DIAMETRO MAX. RUOTA	MAXIMALER RADDURCHMESSER	1100 mm
TIRE WIDTH	LARGHEZZA PNEUMATICO	REIFENBREITE	3" - 14"
BEAD-BREAKER OPENING	APERTURA STALLONATORE	ABDRÜCKVORRICHTUNG ÖFFNUNG	380 mm
BEAD-BREAKING POWER	POTENZA STALLONATURA	ABDRÜCKKRAFT	15000 N
WORKING AIR PRESSURE	PRESSIONE DI ESERCIZIO ARIA	ARBEITSLUFTDRUCK	8 - 10 bar
MOTOR POWER (PEDAL CONTROL TWO SPEED MOTOR)	POTENZA MOTORE (MOTORE A DUE VELOCITÀ CON COMANDO A PEDALE)	MOTORLEISTUNG (PEDALSTEUERUNG MOTOR MIT ZWEI DREHGESCHWINDIGKEITEN)	0,85 KW - 1.1 kW
CHUCK ROTATION SPEED	VELOCITÀ ROTAZIONE MANDRINO	SPANNFUTTER ROTATIONSGESCHWINDIGKEIT	7 rpm - 2V 6.5 - 13 rpm
NOISE LEVEL RUNNING	RUMOROSITÀ DURANTE IL FUNZIONAMENTO	LAUFENDER GERÄUSCHPEGEL	<70 db
NETT WEIGHT MACHINE	PESO NETTO MACCHINA	NETTOGEWICHT MASCHINE	255 Kg
GROSS WEIGHT MACHINE	PESO LORDO MACCHINA	BRUTTOGEWICHT MASCHINE	295 Kg
MAX DIMENSION IMBALLAGE (LXPXH)	DIMENSIONE MAX IMBALLO (LXPXH)	MAX. ABMESSUNGEN VERPACKUNG (LXBXH)	1150X920X1000 mm
FOR 40" CONTAINER	PER CONTENITORE DA 40"	FÜR 40" BEHÄLTER	46 pcs

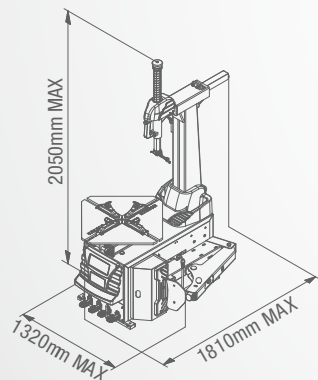

ACCESSORIES - ACCESSORI - ZUBEHÖR



STANDARD



OPTIONAL - OPZIONALI - OPCIONALES *

*For other optional accessories, refer to separate catalogue - Per altri accessori consultare l'apposito catalogo - Weitere Zubehöre Gemäß Verzeichni.

OPTIONAL ACCESSORIES

- CT-S-0200000** - Plastic bead pressing clamp
- CT-S-0110000** - Demount head quick change tool
- CT-S-0310000** - Plastic demount head assy (for tilt back model use)
- C-21-8000100** - Motorcycle demount head
- C-M-0200000** Motorcycle adaptor (hand roller style), for inner adjustable jaws system use
- CT-S-0600000** - Wheel rotation support
- 8-11900271** - Lever and shoe plastic protection kit
- 8-11900270** - Plastic protection kit
- CT-A1-1000000** - Wheel lifter (not yet available)

ACCESSORI OPZIONALI

- CT-S-0200000** - Pinza premitallone in plastica
- CT-S-0110000** - Attrezzo per cambio rapido testina di smontaggio
- CT-S-0310000** - Gruppo testina di smontaggio in plastica (per modelli a ribaltamento)
- C-21-8000100** - Testina di smontaggio motocicletta
- C-M-0200000** - Adattatore motocicletta (stile rullo manuale), per uso con sistema a griffe interno regolabile
- CT-S-0600000** - Supporto rotazione ruota
- 8-11900271** - Kit protezioni in plastica leva e paletta
- 8-11900270** - Kit protezioni in plastica
- CT-A1-1000000** - Sollevatore ruota (ancora non disponibile)

SONDERZUBEHÖR

- CT-S-0200000** - PVC wulsthalteklammer
- CT-S-0110000** - Schnellverschluss Demontagekopf
- CT-S-0310000** - Schnellverschluss Kunststoff-Montagekopf (nur für Modelle mit kippbarer Montagesäule)
- C-21-8000100** - Motorrad-Montagekopf
- C-M-0200000** - Spannadapter innen, für mittelgroße Räder
- CT-S-0600000** - Raddrehhalter
- 8-11900271** - Kit Schutzelemente aus Kunststoff für Hebel und Schaufel
- 8-11900270** - Kit Schutzelemente aus Kunststoff
- CT-A1-1000000** - Radheber für Räder (noch nicht verfügbar)

The manufacturer reserves the right to modify the features of its products at any time - Fotografie, caratteristiche ed i dati tecnici non sono vincolanti, possono subire modifiche senza preavviso. Elles peuvent subir des modifications sans préavis. - Die Fotografien, die angegebenen Eigenschaften und die technischen Daten sind nicht verbindlich und können ohne Vorankündigung geändert werden.

Cod. DPTC000131A_Ed. 02_2019



NEXION SPA - ITALY - Società unipersonale soggetta a direzione e coordinamento di Minio srl - A sole shareholder Minio company
www.tecoautomotive.com - teco@teco.it

